

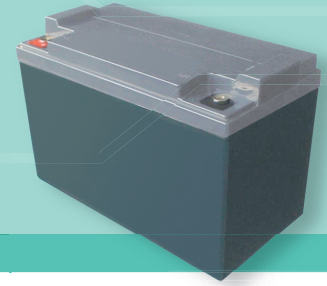

## ESL 100-12



### Innovative Features

- Completely maintenance free, sealed construction eliminates the need for watering
- Fully tank formed plates
- Analytical Grade electrolyte
- Spill proof / leak proof
- Valve regulated Max internal pressure 2.5 psi
- Multi-position usage
- ABS Case and cover - V0 on request
- Low self discharge
- FAA and IATA approved as non-hazardous
- Built to comply with IEC 8962, DIN 43534, BS 6290 Pt4, Eurobat

### Specifications

- Nominal Voltage..... 12 Volts
- Nominal Capacity ..... 110Ah (C20 @ 20 °C)
- Design Life ..... 12 Years
- Operating Temperature... -20 °C to 50 °C
- Grid alloy..... Calcium / Tin lead alloy
- Plates..... Flat Pasted
- Separator ..... Absorbant Glass Mat
- Active material..... Very high purity lead
- Case and cover ..... ABS (VO on request)
- Charge Voltage ..... Float 2.25 - 2.30 VPC @25 °C  
Cycling 2.35 @25 °C  
Max. 2.4 VPC Max ripple 0.05C (A)
- Electrolyte ..... Sulphuric acid Analytical grade purity
- Venting Valve ..... EPDM Rubber 1.5 to 2 psi (10.5 - 14 KPa) release pressure. Resealing at 1 psi (7 KPa)
- Terminal ..... Insert 14mm Dia M6 thread. Epoxy sealed by extended mechanical paths
- Torque setting..... The recommended torque value for all types is 5-7 Nm
- Cables..... Connectors, cables, terminal covers on request.

### Terminal Dimensions

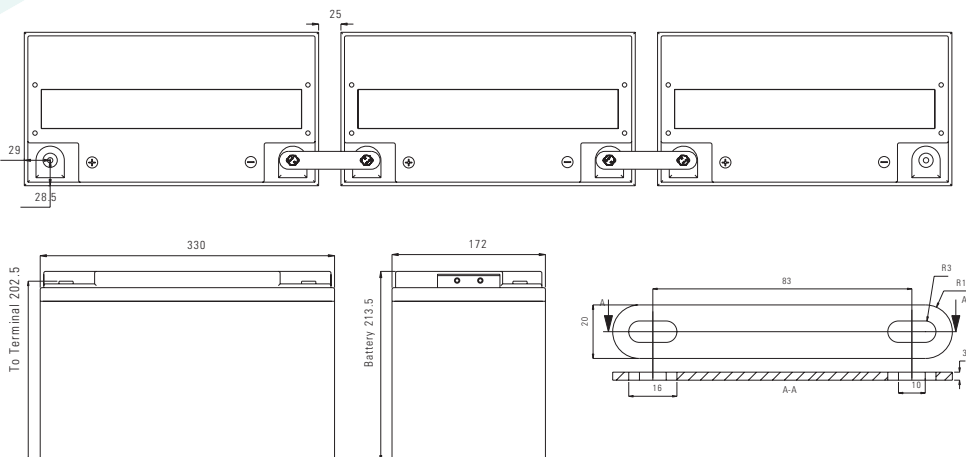

### Specifications

Nominal Voltage	12V		
Nominal Capacity	110 Ah		
Dimensions	Total Height - (Inc. terminal s)	213 mm - n/a mm	8,39 inches - n/a inches
	Length - Width	332 mm - 174 mm	13,07 inches - 6,85 inches
Weight 32,2 Kg - 71,16 lbs			

## Characteristics

Capacity 20 °C (68 °F) To 1.7 volts	20 hour rate 10 hour rate 5 hour rate 1 hour rate 15 min rate Internal Resistance Impedance	109,8 Ah 99,0 Ah 96,4 Ah 69,8 Ah 51,5 Ah 4 mOhms S
Capacity correction for Temperature Variations (C20)	40 °C (104 °F) 20 °C (68 °F) 0 °C (32 °F) -15 °C (5 °F)	102% 100% 85% 65%
Self-Discharge 20 °C (68 °F)	Capacity after 1 months storage Capacity after 3 months storage Capacity after 6 months storage	98% 94% 86%
Short Circuit Current 20 °C (68 °F)	3000	
Terminal	Standard Optional	14mm Insert M6 thread Cu/Lead Flag - J Type - Auto
Charging (Constant Voltage)	Cyclic Float	2.35 - 2.40 VPC (20-25 °C) 2.27 - 2.30 VPC (15-25 °C)

## Constant Power Discharge - Watts per Cell at 20°C

End V per Cell	5M	10M	15M	20M	25M	30M	35M	40M	45M	60M	90M	2 hr	3 hr	4 hr
1.85	461	376	311	268	234	212	189	171	155	124	91.6	71.8	50.0	38.5
1.80	570	446	352	292	256	225	198	180	165	130	93.1	73.0	50.7	39.1
1.75	582	471	371	308	264	229	202	183	166	131	93.5	73.4	50.7	39.2
1.70	603	474	375	313	267	231	205	184	168	132	95.0	74.8	52.1	40.4
1.65	634	482	380	315	270	234	207	187	170	133	96.0	75.1	52.3	-
1.60	661	497	391	320	272	237	209	189	171	134	97.3	75.5	52.5	-

## Constant Amps discharge - Amps at 20°C

End V per Cell	5 M	10 M	15 M	20 M	25 M	30 M	35 M	40 M	45 M	60 M	90 M	2 hr	3 hr	4 hr	5 hr	8 hr	10 hr	12 hr	20 hr
1.85	248	201	166	142	124	112	99.4	89.9	81.3	64.6	47.5	37.1	25.6	19.6	16.0	11.0	9.00	7.70	5.12
1.80	311	242	191	158	137	120	105	95.4	86.9	68.2	48.5	37.9	26.1	20.1	16.6	11.3	9.31	7.96	5.31
1.75	321	259	202	167	142	123	108	97.4	88.3	69.0	48.9	38.2	26.2	20.2	16.7	11.4	9.36	8.01	5.33
1.70	336	262	206	171	145	125	110	98.7	89.3	69.8	49.9	39.0	27.0	20.8	17.1	11.7	9.64	8.25	5.49
1.65	355	268	209	173	147	127	111	100	90.8	70.4	50.5	39.3	27.1	-	-	-	-	-	-
1.60	371	277	216	176	148	129	113	102	91.4	71.0	51.2	39.5	27.3	-	-	-	-	-	-

## Ampere Hour at 20 °C

End V per Cell	2 hr	3 hr	4 hr	5 hr	8 hr	10 hr	12 hr	20 hr
1.85	74.1	76.8	78.4	80.1	88.0	90.0	92.4	102
1.80	75.7	78.3	80.2	82.8	90.3	93.1	95.5	106
1.75	76.4	78.7	80.8	83.3	91.1	93.6	96.1	107
1.70	78.0	81.1	83.4	85.7	93.7	96.4	99.0	110
1.65	78.5	81.4	-	-	-	-	-	-
1.60	79.0	81.9	-	-	-	-	-	-